

# 2025 Customer Training Catalog

Training options to meet your needs.



The power behind **your mission**





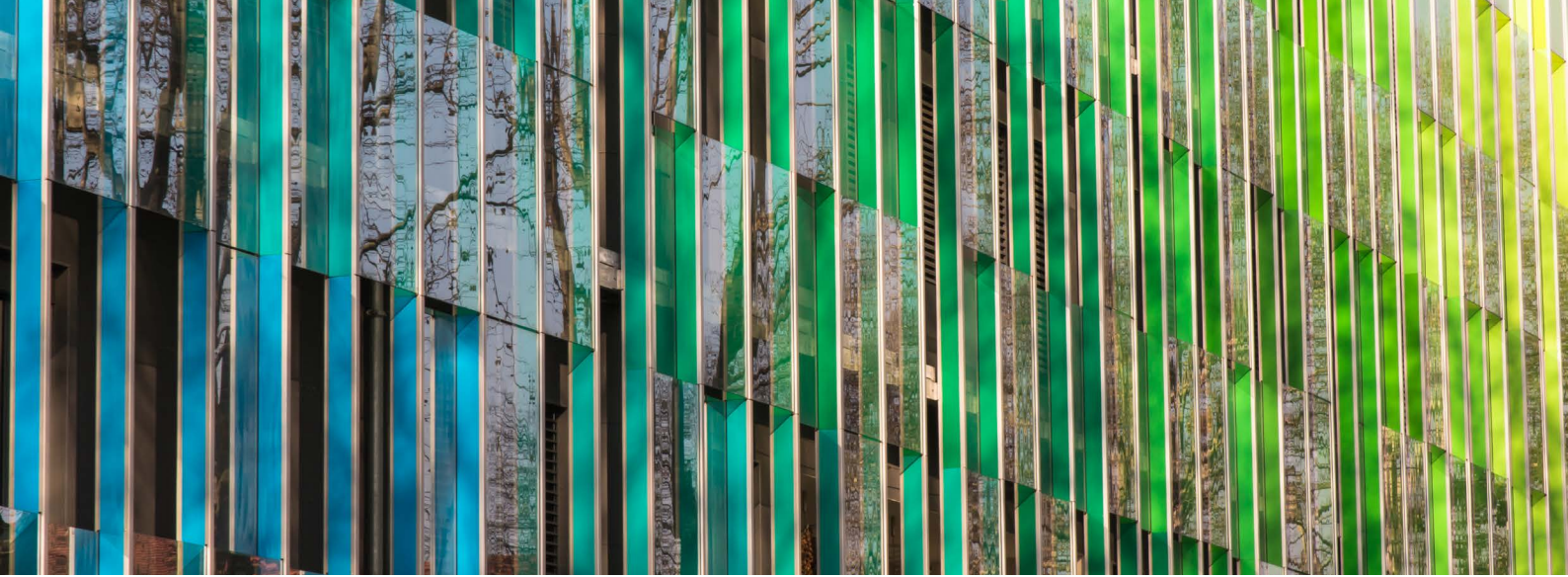

# Table of Contents

---

## Course Details and Information

### Institute

About the Johnson Controls Training Institute.....	3
Training Options to Meet Your Needs.....	4
Enrollment Information .....	5
Training Institute Locations and Hotels.....	6

### Typical Sequence of Courses

HVAC Industry.....	10
Metasys® Systems.....	23
Facility Explorer® .....	24
Metasys® Validated Environments.....	25
Instructor-Led Virtual Learning Courses.....	38
Courses Offered By Request Only.....	53

### Application for Enrollment

Course Application.....	57
-------------------------	----



# About the Johnson Controls Training Institute

Since 1947, the Johnson Controls Training Institute has been helping people succeed at creating and managing quality building environments. The Training Institute partners with engineering schools, technical colleges, and experts in the building environments industry. This allows us to provide high-quality learning experiences that reflect both the current state of the industry today and the direction its heading in the future.

Our curriculum has been developed by professional instructors who are experienced in the building environments industry. Their extensive real-world experience and ability to share their knowledge in a structured format assures you an enlightening and productive educational experience.

- Learn from Certified Instructors\* with years of industry experience
- Experiment in our labs, using specially designed equipment simulators
- Find the learning opportunities
- Expand your knowledge in industry topics such as:
  - Building Automation Systems
  - Energy Management
  - Heating, Ventilating, and Air Conditioning Systems
  - Preventative Maintenance
  - Automated Building Controls

Because your goal is to apply what you've learned, our state-of-the-art facilities include fully equipped labs for hands-on exercises. Portable equipment simulators enable the Training Institute to bring many of its courses to your location, yet still enable you to practice what you've learned without jeopardizing building operations.

Our comprehensive and cost-effective programs are designed for anyone who needs a working knowledge of environmental systems, including:

- Building Owners
- Building Managers
- Engineers
- Operators
- Maintenance Technicians
- Property Managers

*\*Johnson Controls Training Institute instructors are certified on the technical and application objectives of each course, while referencing the core instructor competencies summarized by the International Board of Standards for Training, Performance, and Instruction (IBSTPI) Instructor Competencies - The Standards (Volume 1) ©2003, all rights reserved.*





# Training Options to Meet Your Needs

Our learning opportunities are designed to provide you with the knowledge and skills necessary to effectively and efficiently operate your building's systems. By using your newly acquired abilities, you can maximize the potential of your building systems and increase your return on investment. To help you take advantage of the benefits of our training, we offer several ways to approach our courses. You can select from our:



## Training Institute Courses (Scheduled)

Regularly scheduled courses with both a classroom and lab component are conducted at our eleven Johnson Controls Training Institute locations. During class you will be using an iPad® to take notes and highlight the material. When class ends you will take your notes and course material with you on a USB Drive. The descriptions of the regularly scheduled courses begin on page 10. Refer to the Class Schedule available at [www.johnsoncontrols.com/institute](http://www.johnsoncontrols.com/institute) for the dates, locations, and prices of these courses. Note: No audio/visual recording equipment is allowed.

## Instructor-Led Virtual Learning Courses

Learn in the convenience of your own home, office, or work location using Johnson Controls instructor-led virtual learning courses. Our instructor-led virtual learning courses can be used as preparation for a course, to refresh skills, or to provide an effective learning alternative if attendance at a typical classroom course is impractical. The list of instructor-led virtual learning courses are on page 38.

## Courses Offered By Request Only

Some of our courses target a more specific audience and therefore, have lower demand. To continue to satisfy the needs of those who still occasionally need these courses, selected courses are only conducted upon request. These courses can be conducted at your site or at one of our eleven Training Institute locations. For this reason, these courses are not included on the schedule. To inquiry about scheduling a course, contact the Learning Institute at 414-524-4286 or [cg-customer.registrar@jci.com](mailto:cg-customer.registrar@jci.com).

## Schedule of Classes

The 2025 schedule of classes is available at [www.johnsoncontrols.com/institute](http://www.johnsoncontrols.com/institute). The schedule is subject to change.

## Onsite Learning Programs

Johnson Controls Training Institute can help you make the most of your investment in learning by bringing our instructors and classes to you or to the location of your choice. More and more companies are realizing the value of bringing training Onsite. Our onsite Courses can be the most efficient and cost-effective way to train as few as five employees.

### Onsite Courses offer a number of advantages:

- Smaller class size allows for more individualized attention
- Economical as one instructor travels instead of eight or more students
- Consistency among employees who learn together as a group

### To ensure the success of an onsite Course, you provide:

- A minimum of five students
- A suitable room for training

### Johnson Controls Training Institute will provide:

- Specially designed portable equipment simulators and computers
- USB jump drives with course and reference material for all student



# Enrollment Information



## ONLINE ENROLLMENT

To browse our catalog and enroll for our courses, please visit our website:

[www.jcittraininginstitute.com](http://www.jcittraininginstitute.com)

For more information, call or fax:  
414-524-4286 or 800-524-8540  
877-403-6625 (fax)

[cg-customer.registrar@jci.com](mailto:cg-customer.registrar@jci.com)

### Payment:

Payment can be made using Visa®, MasterCard® or American Express®.

All necessary course materials are included in the tuition listed in each course description

### Substitutions and Cancellations

Circumstances may occur that could prevent you or your employee from attending a course for which you are enrolled. For this reason, we allow you to substitute another employee in their place at no additional fee. If no substitute student is available and you must cancel your enrollment, a refund will be issued by visiting [www.jcittraininginstitute.com](http://www.jcittraininginstitute.com) at least 10 business days prior to the start of the course. If, however, you must cancel within 10 business days of the start of the course, you will be liable for the entire course fee.

Johnson Controls reserves the right to cancel classes and assumes no liability for expenses. All registrants will be notified at least ten days before the start of class should a course be canceled.

### Guarantee

We stand behind our courses with the following guarantee:

If, by the midpoint of the course, you are not satisfied with the course you are taking, Johnson Controls Training Institute will refund your tuition fee in full, or give you credit toward another course or packaged training program.



# Training Institute Locations & Hotels



## Boston Massachusetts

39 Salem Street, Lynnfield, MA 01940  
Located approximately 12 miles from Boston's Logan International Airport. Airport Code: BOS

### Suggested Hotels:

**Four Points by Sheraton Wakefield Boston Hotel & Conference Center**  
1 Audubon Road, Wakefield, MA 01880, 781-245-9300

**Hampton Inn**  
59 Newberry Street (Route1) Peabody, Ma 01960  
978-536-2020

**SpringHill Suites by Marriott**  
43 Newberry Street (Route 1) Peabody, Ma 01960  
978-535-5000



## Dallas Texas

3021 West Bend Drive, Irving, TX 75063  
Located 6 minutes from the Dallas Fort Worth International Airport. Airport Code: DFW

### Suggested Hotels:

**Element**  
3550 W. IH 635, Irving, TX 75063  
972-929-9800

**Hyatt House Dallas/Las Colinas**  
5901 N MacArthur Blvd, Irving TX 75039  
972-831-0909

**Hilton Garden Inn Las Colinas**  
7516 Las Colinas Blvd, Irving TX 75063  
972-444-8434

**Staybridge Suites - DFW Airport North**  
2220 Market Place Blvd, Irving TX 75063  
972-401-4700



# Training Institute Locations & Hotels



## Houston Texas

4111 Greenshadow Drive, Pasadena, TX. 77536

Located approximately 12 miles from the Houston/Hobby Airport and 28 miles from George Bush Intercontinental Airport. Airport Code: IAH and HOU

### Suggested Hotels:

#### Hampton Inn & Suites Houston/Pasadena

4741 E Sam Houston Parkway South  
Pasadena TX 77505  
281-998-3300

#### Holiday Inn Express & Suites Deer Park

201 W X Street  
Deer Park, TX 77536  
281-479-9888

#### Comfort Suites Deer Park Pasadena

1501 Center Street  
Deer Park, TX 77536  
281-930-8888



## Louisville Kentucky

9410 Bunsen Parkway, Suite 100,  
Louisville, KY 40220

Located approximately 10 miles from Louisville International Airport. Airport Code: SDF

### Suggested Hotels:

#### Holiday Inn Louisville East - Hurstbourne

1325 South Hurstbourne Parkway  
Louisville, KY 40220  
502-426-2600

#### Hyatt Place - East

701 South Hurstbourne Parkway  
Louisville, KY 40222  
502-426-0119





# Training Institute Locations & Hotels

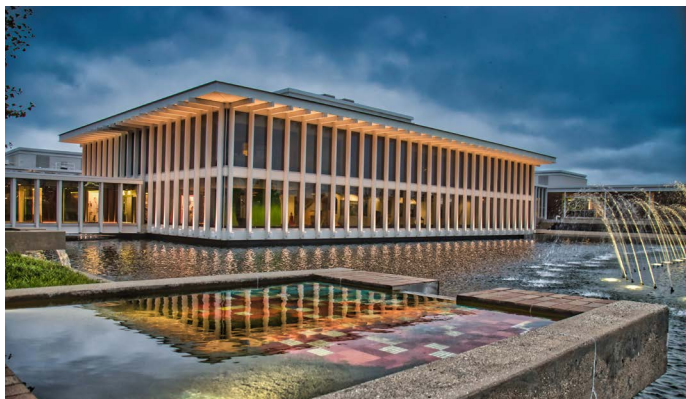

## Milwaukee Wisconsin

5757 North Green Bay Avenue  
Milwaukee, WI 53209

Located in downtown Milwaukee, approximately 16 miles from General Mitchell International Airport. Airport Code: MKE

### Suggested Hotels:

#### Residence Inn Milwaukee North / Glendale

7003 N. Port Washington Road, Glendale, WI 53217  
414-446-4295

#### Holiday Inn Milwaukee Riverfront

4700 North Port Washington Road, Milwaukee, WI 53212  
414-962-6040

Students must call the hotels directly to make reservations. The Johnson Controls Training Institute rate must be requested. Reservations made through a travel agency are not eligible for the discounted rate.



## Phoenix Arizona

Gateway Community College, 108 N. 40th Street, Phoenix, AZ 85034

Located about one mile north of the Phoenix Sky Harbor International Airport. Airport Code: PHX

### Suggested Hotels:

#### Crowne Plaza Phoenix

4300 East Washington Street  
Phoenix, AZ 85034  
602-273-7778

#### Hampton Inn

601 North 44th Street, Phoenix,  
AZ 85008  
602-267-0606

#### Hilton Garden Inn

3838 East Van Buren Street  
Phoenix, AZ 85008  
602-306-2323





# Training Institute Locations & Hotels



## TAMPA Florida

3802 Sugar Palm Dr, Tampa FL 33619  
Located 12 miles from the Tampa International Airport. Airport Code: TPA

### Suggested Hotels:

#### Residence Inn Tampa Sabal Park/Brandon

9719 Princess Palm Avenue, Tampa, FL 33619  
813-627-8855

#### Fairfield by Marriott

6720 Lakeview Center Drive, Tampa, FL 33619  
(813) 626-3000

#### Holiday Inn Express & Suites

8610 Elm Fair Blvd, Tampa, FL 33610  
(813) 490-1000

#### Staybridge Suites Tampa East Brandon

3624 North Falkenburg, Tampa, FL 33619  
813-227-4004



## New Freedom PA

5000 Renaissance Drive, New Freedom, PA 17349  
Located 52 miles from the Baltimore Washington International Airport and 47 miles from the Harrisburg International Airport.  
Airport Code: BWI & MDT

### Suggested Hotels:

#### Home2 Suites by Hilton York

212 Pauline Drive, York, PA 17402  
717-747-0360

#### Best Western Plus

140 Leader Heights Road, York, PA 17403  
717-741-1000

#### Hampton Inn & Suites Hilton York South

2159 South Queen Street, York, PA 17402  
717-741-0900

#### Shrewsbury Hampton by Hilton

1000 Far Hills Drive, New Freedom, PA 17349  
717-235-9898



# Typical Sequence of HVAC Industry Courses

*Click on each tab to learn more.*

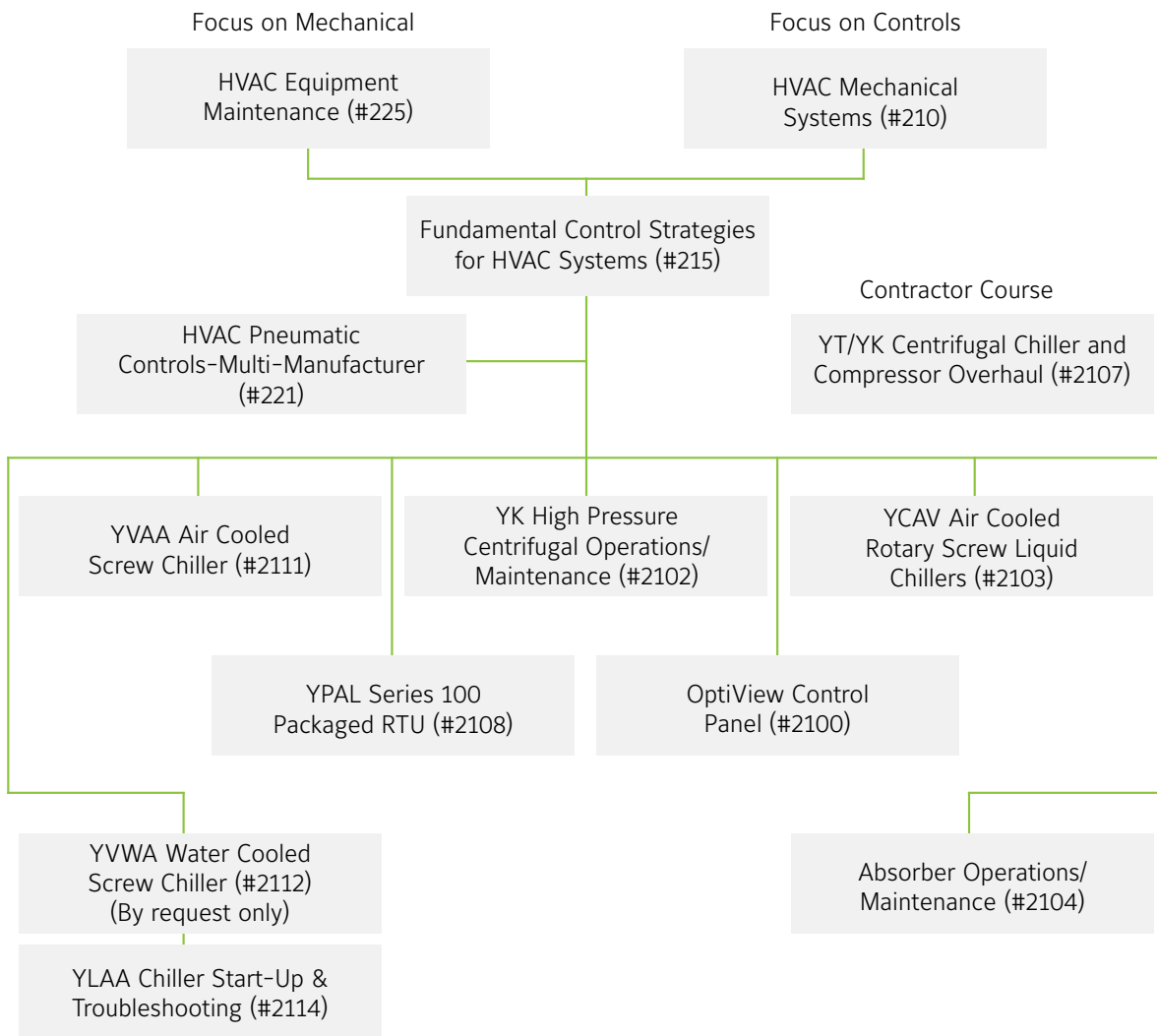





## HVAC Industry Courses

### HVAC Mechanical Systems Course #210, 3.0 CEU

The fundamentals of HVAC mechanical equipment operation are taught in this survey, hands-on course. Designed for personnel responsible for the selection, design, installation, calibration or maintenance of HVAC mechanical equipment. It emphasizes hands-on activities with boilers, chillers, air handlers and other operating equipment from a variety of manufacturers. Students will gain a comprehensive understanding of operating principles and the proper use of test instruments to verify equipment performance.

#### Course Topics

- HVAC System Types and Piping Systems
- Psychrometrics
- Air Handlers, Types and Characteristics
- Fans and Fan Characteristics
- Dampers and Damper Actuators
- Valves and Valve Actuators
- Facility Management Systems
- Controls and Components
- Boilers and Boiler-Related Equipment
- Heat Exchangers and Pumps
- Refrigeration Fundamentals
- Reciprocating Chillers and Accessories
- Centrifugal Chillers
- General Troubleshooting
- Hands on Lab
- Final Review

[ENROLL NOW](#)

#### Course Duration

Monday - Friday  
Class ends at 11:30 a.m. on Friday

#### Course Fee

\$3565  
per student







## HVAC Industry Courses

### Fundamental Control Strategies for HVAC Systems – Course #215, 3.0 CEU

This introductory course is designed for anyone who operates, maintains or troubleshoots HVAC control systems. Students will analyze a number of HVAC Systems and their associated controls, including central plant, air and water distribution and terminal systems. The strategies learned can be applied to any controls system type or manufacturer.

#### Course Topics

- HVAC Environment, Systems and Controls
- Psychrometrics, Air Properties and HVAC Processes
- Control System Fundamentals
- Sensor Types and Applications
- Controls System Configurations
- Feedforward and Feedback Control Loops
- Reset Control Strategies
- Controlled Devices: Valves, Dampers, and Actuators

- Hot/Chilled Water Distribution Systems
- Control Strategies for Water Distribution Systems
- Hot/Chilled Water Terminal Systems
- Control Strategies for Water Terminal Systems
- Air Distribution Systems
- Control Strategies for Air Distribution Systems
- 100% OA System Control Strategies
- Mixed Air System Control Strategies
- Variable Air Volume Control Strategies
- VAV Terminal Unit Control Strategies
- Introduction to Facility Management Systems
- Hands on Lab
- Final Review

Course Duration
Monday - Friday Class ends at 11:30 a.m. on Friday
Course Fee
\$3565 per student



**ENROLL NOW**





## HVAC Industry Courses

### HVAC Pneumatic Controls - Multi - Manufacturer - Course #221, 2.0 CEU

This course provides a comprehensive overview of maintenance requirements, calibration procedures and troubleshooting techniques. Hands-on lab exercises emphasize calibrating and troubleshooting using pneumatic controls from a variety of manufacturers.

#### Recommended Prerequisite:

Fundamental Control Strategies for HVAC Systems (#215) or HVAC Mechanical Systems (#210) or equivalent experience

#### Course Topics

- Pneumatic Air Supply and Distribution Systems
- Room Control - Thermostats and Humidistats
- Relation of Controller and Controlled Device
- Single Setpoint Room Controllers, Thermostats and Humidistats

- Dual Setpoint Room Controllers
- Pneumatic Controlled Devices: Valves, Dampers, Actuators, Pilot, Positioners
- Auxiliary Devices
- Pneumatic Transmitters (Remote Sensing)
- Single Input Receiver Controllers
- Dual Input Receiver Controllers

[ENROLL NOW](#)

#### Course Duration

Tuesday - Thursday  
Class ends at 3:30 p.m. on Thursday

#### Course Fee

\$2915  
per student







## HVAC Industry Courses

### HVAC Equipment Maintenance Course #225, 2.0 CEU

This introductory course provides an overview of the maintenance tasks and techniques that are typically required on HVAC equipment. Individuals new to HVAC maintenance, managing a maintenance function or desiring a refresher will benefit. Students will learn how to perform proper maintenance, safety procedures and basic troubleshooting techniques.

#### Course Topics

- Overview of HVAC
- Electrical Systems
- OSHA Lockout/Tagout Training
- Refrigeration Maintenance & Troubleshooting
- Centrifugal Systems Overview
- Pump Maintenance
- Cooling Towers
- Air Handling Systems
- Boilers
- Air Compressor Maintenance
- Hands on Lab
- Final Review

#### Course Duration

Tuesday - Thursday  
Class ends at 3:30 p.m. on Thursday

#### Course Fee

\$2915  
per student

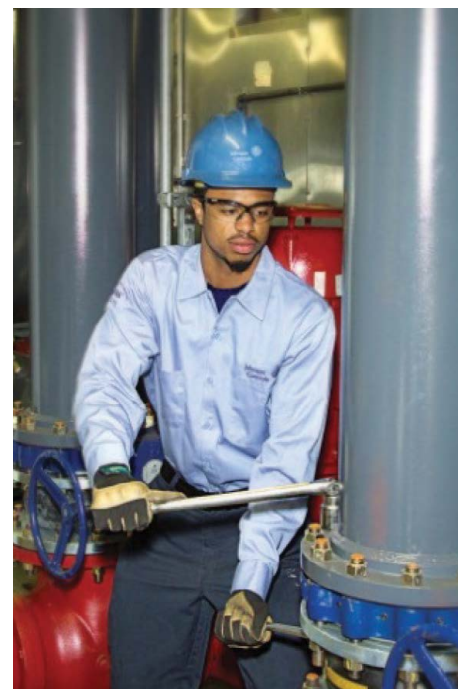

[ENROLL NOW](#)





## HVAC Industry Courses

### OptiView Control Panel Course #2100, 1.3 CEU

This two-day course for service personnel covers the OptiView graphic micro-processor control center. Basic navigation, panel architecture, operation and service of the OptiView Control Centers are covered in this course. Labs include hands-on training using OptiView Control Panel simulators.

#### Course Topics

- OptiView Basics
- OptiView Architecture: Component Identification, Location and Functionality
- OptiView Operation: Screen Navigation, Program Download, Codes, Configuration Setup, System Commissioning Checklist
- System Calibration, Service Setpoints and Reset Procedures
- Electro-Mechanical Starter Board
- Solid State Starter Board

- Variable Speed Drive Board
- High Speed Thrust Bearing Limit Switch
- Proximity Probe, Refrigerant Level Control
- Sale Order Data, Custom User ID and Password, Record Setpoint Changes
- High Condenser Pressure Warning Threshold
- Smart Freeze Protection
- Diagnostics and Troubleshooting
- Advanced Diagnostics, Trend Screen Setup
- Hands on Lab

#### Course Duration

Tuesday - Wednesday  
Class ends at 3:30 p.m. on Wednesday

#### Course Fee

\$2160  
per student



[ENROLL NOW](#)





## HVAC Industry Courses

### YK High Pressure Centrifugal Operations/Maintenance Course #2102, 2.0 CEU

Students will learn about the internal workings of the YK high-pressure centrifugal single-stage compressor, oil return system, OptiView Control Center and other components and subsystems. A comprehensive review of the preventive maintenance schedule and system capacity checkout procedure is also covered.

- OptiView Operation: Screen Navigation, Interpretation, and Modification
- Maintenance
- Troubleshooting
- Warranty
- OptiView Simulator Hands on Lab
- Evaluating Chiller Performance

#### Course Topics

- Centrifugal Compressor Theory of Operation
- YK Chiller Design and Component Functionality
- YK Seasonal Start-up
- OptiView Basics: Application, Terminology
- OptiView Architecture: Component Identification, Component Location

Course Duration
Tuesday - Thursday Class ends at 3:30 p.m. on Thursday
Course Fee
\$2915 per student



**VIRTUAL COURSES AVAILABLE**

**ENROLL NOW**





## HVAC Industry Courses

### YCAV Air Cooled Rotary Screw Liquid Chillers\* Course #2103, 2.0 CEU

This three-day course teaches service personnel about the YCAV Chiller features, including the screw compressor, system ancillary components, unit operation and maintenance. \*Dress code: For safety, closed-toe, leather shoes and long pants are required.

#### Course Topics

- Screw Chiller Basics
- Basic Electronics
- VSD Basics
- VSD and Control Panel Architecture
- Operation and Sequencing
- Latitude Simulator Exercises
- Information and Safety, Handling and Storage
- VSD Operation and Faults
- Maintenance
- Unit Troubleshooting
- Hands on Lab

#### Course Duration

Tuesday - Thursday  
Class ends at 3:30 p.m. on Thursday

#### Course Fee

\$2915  
per student



VIRTUAL COURSES AVAILABLE

ENROLL NOW





## HVAC Industry Courses

### Absorber Operations/Maintenance Course #2104, 2.0 CEU

This course teaches operators and technicians about the operation and controls associated with the YORK® lithium bromide absorption chillers. Absorption theory including P/T relationships and solution chemistry are also covered. The operation and operating procedures for both Isoflow (single stage) and Paraflow systems (two stage) are reviewed with an emphasis on preventive maintenance procedures.

#### Course Topics

- Basic Refrigeration Principles
- Units of Measure, Types of Heat
- Absorption Principles
- Solution Chemistry
- YIA Components and Cycle
- Water Circuits
- YPC Components and Cycle
- YPC Purge System

- Operating Information, Setpoints & Warnings
- System and Safety Cycling Shutdowns
- Operation and Maintenance
- Crystallization
- Unit Operation and Operational Limitations
- Refrigerant Contamination
- Heating/Cooling Changeover
- Preventive Maintenance
- Schedules
- Hands on Lab

#### Course Duration

Tuesday - Thursday  
Class ends at 3:30 p.m. on Thursday

#### Course Fee

\$2915  
per student



VIRTUAL COURSES AVAILABLE

ENROLL NOW





## HVAC Industry Courses

### YT/YK Centrifugal Chiller and Compressor Overhaul\* Course #2107, 3.3 CEU

Service personnel will become familiar with the operation and maintenance of centrifugal systems. Students will review R-11, R-123, R-22 and R-134a single stage centrifugal chillers. They will also learn the internal workings of the compressor, oil return system, lube circuit, purge and heat exchangers. The OptiView Control Center plus preventive maintenance and system checkout procedures are also addressed along with a hands-on teardown and rebuild of a YK centrifugal compressor. \*Dress code: For safety, closed-toe, leather shoes and long pants are required.

#### Course Topics

- Refrigeration Theory
- Centrifugal Compressor Theory of Operation
- YT/YK Chiller Design and Component Functionality

- YT/YK Maintenance
- Seasonal Start-up
- Unit Troubleshooting
- Compressor Teardown/Reassembly
- OptiView Basics
- OptiView Operation
- OptiView Start-up and Troubleshooting
- High Speed Thrust Switch
- Proximity Probe
- Refrigerant Level Control
- Oil Pump Variable Speed Drive
- Hands on OptiView Labs

Course Duration
Monday - Friday Class ends at 3:30 p.m. on Friday
Course Fee
\$3510 per student



**ENROLL NOW**





## HVAC Industry Courses

### YPAL Series 100 Packaged RTU Course #2108, 1.3 CEU

Students will learn the theory of operation of the Constant Volume and Variable Volume Eco2 Rooftop Unit. Component functions, subsystems are also discussed, along with an introduction to the FlexSys Systems. The students will become familiar with the unit's wiring and communication cards, and the programming and sequence operation.

**Recommended Prerequisites:**  
Entry to Mid- level Technician

#### Course Topics

- Safety Review
- Eco2 System Overview
- Constant Volume/Variable Volume Systems
- Eco2 Physical Data
- Unit Wiring
- Introduction to FlexSys System
- BAS Communication
- IPU Architecture
- Unit Configuration and Start-up
- Programming and Sequence of Operation

#### Course Duration

Tuesday - Thursday  
Class ends at 3:30 p.m. on Thursday

#### Course Fee

\$2915  
per student

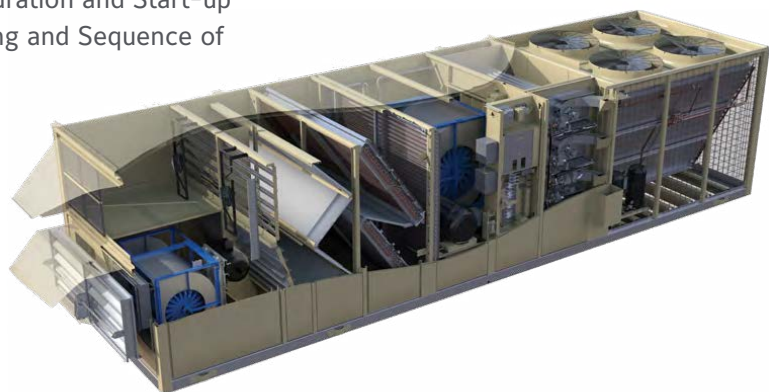

**ENROLL NOW**





## HVAC Industry Courses

### YVAA Air Cooled Screw Chiller\* Course #2111, 2.0 CEU

This three-day course teaches experienced service technicians about the YVAA Chiller. The course will include features of this unit and the differences in installation, operation and maintenance from the YCAV. \*Dress code: For safety, closed-toe, leather shoes and long pants are required.

#### Recommended Prerequisites:

- Working knowledge of the YCAV/ YCIV Chiller
- Working knowledge of VSDs
- Understanding of basic electronics

#### Course Topics

- Chiller layout and components
- Safety, handling
- Installation
- Operation/Maintenance
- VSD
- Simulation Exercises

#### Course Duration

Tuesday - Thursday  
Class ends at 3:30 p.m. on Thursday

#### Course Fee

\$2915  
per student



VIRTUAL COURSES AVAILABLE

ENROLL NOW





## HVAC Industry Courses

### YLAA Chiller Start-up & Troubleshoot, Course #2114, 2.0 CEU

Students will learn the techniques, strategies and skills required to operate, repair, start-up and maintain York® YLAA chiller and YLPA heat pump chillers using multiple scroll compressors in each system. The techniques acquired in this course may be applied to other York® small tonnage chillers and condensing units such as YCAL, YLUA and YCUL models.

#### Course Topics

- Safety
- Literature
- Theory
- Components

- Operations
- Wiring Diagrams
- Installation
- Startup
- Maintenance
- Evaluating Performance
- Warranty

#### Course Duration

Tuesday - Thursday  
Class ends at 3:30 p.m. on Thursday

#### Course Fee

\$2915  
per student



VIRTUAL COURSES AVAILABLE

ENROLL NOW





# Typical Sequence of Courses for Metasys® Systems



Click on each tab to learn more.

Metasys® System Extended Architecture for Building Operators (#388)

OR

Metasys® User Interface (UI) for Building Operators (#4800)

Focus on Maintenance and Troubleshooting

Metasys® DX-9100 Operations/Troubleshooting (#365) (By request only)

Learning CCT Hardware and Commissioning (#4802)

Metasys® extended architecture Hardware and Troubleshooting (#4718)

Metasys® System Extended Architecture for Building Operators (#389)

OR

Metasys® User Interface (UI) for Building Engineers (#4801)

Focus on Engineering and Programming

Building Standard CCT Programming (#4803)

Optimizing Strategies for CCT (#4804)

Building and Modifying Metasys® Databases with System Configuration Tool SCT (#4805)

Metasys® System Extended Architecture Advanced Engineering (#397)

Metasys® User Interface Graphics Editor (#3022) (Virtual Instructor Led)

# Typical Sequence of Courses for Facility Explorer®



*Click on each tab to learn more.*

Focus on Engineering  
and Programming

Facility Explorer® (FX)  
Field Controller Engineering (#4714)

Optimizing Strategies for CCT  
Programming with Facility Explorer  
Systems' (#3028)

Facility Explorer® (FX)  
N4 TCP Certification (#4720)

Building and FX Supervisory  
Network Controller (SNC)  
(#3821)





# Typical Sequence of Courses for Metasys® Validated Environments



*Click on each tab to learn more.*

## Engineers

Building Standard CCT Programming (#4803)

Metasys® System Extended Architecture Advanced Engineering (#397)

Optimizing Strategies for CCT Programming (#4804)

## Designers

Building and Modifying Metasys® Databases with System Configuration Tool SCT (#4805)

# Metasys® Systems

## Metasys® System Extended Architecture for Building Operators Course #388, 2.0

This three-day course teaches building personnel how to make the most effective and efficient use of the features of a Metasys® system extended architecture building management system. This course is for building personnel who have Site Management Portal (SMP™ installations of Metasys® system extended architecture).

- Scheduling
- Setting Up Alarms
- Responding to Alarms
- Trending
- Totalization
- Graphics
- Hands on Lab
- Final Review

### Course Topics

- Metasys® System Extended Architecture Overview
- Help File System
- Basic Navigation of the System with the User Interface
- Commanding Objects

Course Duration	
Monday - Wednesday Class ends at 3:30 p.m. on Wednesday	
Course Fee	
<b>\$2915</b> per student	

Status	Item	Value	Description
High Alarm	ZN-T	82.1 deg F	Zone Temperature
	OCC-SCHEDULE	Occupied	Occupied Command
	SF-C	On	Supply Fan Command
	SF-S	On	Supply Fan Status
	DA-T	54.9 deg F	Discharge Air Temperature
	DAT-SP	55.0 deg F	Discharge Air Temperature Setpoint
	CLG-O	99 %	Cooling Valve Output
	PH-O	0 %	Preheat Valve Output
	FILT-S	Clean	Filter Status
	DA-SD	Normal	Discharge Air Smoke Alarm
	LT-A	Normal	Low Temperature Alarm

VIRTUAL COURSES AVAILABLE

ENROLL NOW

26





# Metasys® Systems

## Metasys® System Extended Architecture for Building Engineers Course #389, 3.0

This course teaches building personnel how to make the most effective and efficient use of the features of a Metasys® system extended architecture building management system. This course contains additional topics not covered in the Metasys® system extended architecture for Building Operators course.

### Course Topics

- Metasys® System Extended Architecture Overview
- Help File System
- Basic Navigation of the System with the User Interface
- Commanding Objects
- Scheduling
- Setting Up Alarms
- Responding to Alarms

- Trending
- Totalization
- Graphics
- Setting Up Passwords
- User Views
- Audit Trails
- Sending Reports to Printers, Pagers, Emails, etc.
- Adding Inputs and Outputs to a Controller
- Reviewing Control Strategies
- Backing Up the Data
- Hands on Lab
- Final Review

### Course Duration

Monday - Friday  
Class ends at 11:30 a.m. on Friday

### Course Fee

\$3565  
per student

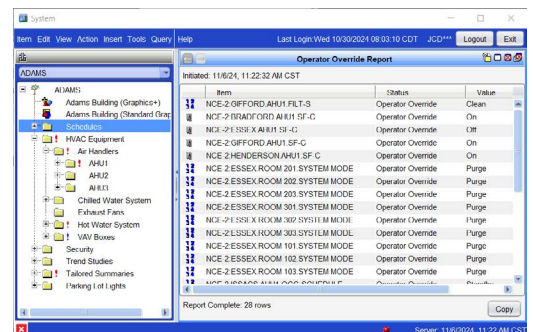

**ENROLL NOW**



# Metasys® Systems

## Metasys® System Extended Architecture Advanced Engineering Course #397, 2.0

Experienced personnel will learn how to write advanced programs for facility-wide or specific mechanical control applications using the System Configuration Tool (SCT). Students will build, modify and troubleshoot routines they create.

### Recommended Prerequisites:

Student must have background in operating and/or engineering the Metasys® system extended architecture. Metasys® system extended architecture Engineering and Setup (#391) or Metasys® system extended architecture for Building Engineers (#389).

**For End Users and/or Metasys® Authorized Building Controls Specialists/Contractors only.**

### Course Topics

- Review Metasys® system extended architecture
- Control Objects (Interlocks, Multiple Commands, LCT, etc.)
- Reset Strategies
- Sequencing Equipment
- Rotation of Equipment
- Operating Equipment per Load Needs
- Lead Lag Strategies
- Creating Calculations Including Tonnage, Highest Daily, Temperature, etc.
- Student Directed Topics and Activities
- Hands on Lab
- Final Review

Course Duration
Tuesday - Thursday Class ends at 3:30 p.m. on Thursday
Course Fee
\$2915 per student

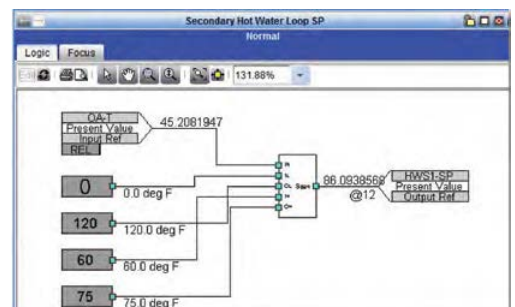

**ENROLL NOW**





# Metasys® Systems

## Metasys® User Interface (UI) for Building Operators #4800 1.3 CEU

### Metasys® User Interface (UI) for Building Operators

This entry level course is intended to assist building operators become proficient in navigating their Building Automation System (BAS) through Metasys® User Interface (UI). Students will leave the class with the confidence and understanding of how to monitor their facility, assess out of ordinary situations, and take appropriate action. Topics are supported by hands-on lab activities to enforce the learning experience.

### Course Topics

- Building Automation Systems (BAS) Overview
- Metasys User Interface (UI) Overview
- Navigating the Metasys User Interface

- Standard Daily Operations in the Metasys UI
- Alarms
- Taking Actions
- Trends
- Schedules and Exceptions
- Advanced Search & Reporting
- Views
- Final Review Course

Course Duration
Tuesday - Wednesday Class ends at 4:00 p.m. on Wednesday
Course Fee
\$2160 per student



[ENROLL NOW](#)



# Metasys® Systems

## Metasys® User Interface (UI) for Building Engineers Course #4801

### Metasys® User Interface (UI) for Building Engineers

This course teaches building personnel how to make the most effective and efficient use of the features of a Metasys® system extended architecture building automation system utilizing the Metasys User Interface (UI). This course contains additional topics not covered in the Metasys system extended architecture for Building Operators course utilizing the Metasys User Interface (UI).

### Course Topics

- Building Automation Systems (BAS) Overview
- Metasys User Interface (UI) Overview
- Navigating the Metasys User Interface
- Standard Daily Operations in the Metasys UI
- Alarms

- Taking Actions
- Trends
- Schedules and Exceptions
- Advanced Search & Reporting
- User Menu Overview
- System Activity
- Graphics Manager (Overview)
- Remote Notifications
- Trend Study Manager
- Dashboard Manager
- Cyber Health Dashboard
- Device Pairing
- BACnet/SC Management
- Site Settings
- User Management
- Space Authorization
- Creating Schedules and Calendars
- Programming Features
- Engine Commands (Review)
- Adding Points
- Adding Extensions (Trends/Alarms/Totalizations)
- Final Review

### Course Duration

Tuesday - Friday  
Class ends at 03:30 p.m. on Friday

### Course Fee

\$3240  
per student



[ENROLL NOW](#)





# Metasys® Systems

## Learning CCT Hardware and Commissioning Course #4802, 2.0 CEU

### Learning CCT Hardware and Commissioning

Designed as a beginner's course for people working with JCI BACnet® field controllers, this course instructs students on how to connect to the controllers and how to download and test the existing control programs. It also covers calibration of input sensors and setup and verification of inputs and outputs. This course is designed for building personnel who want to better understand field controller operation, commissioning, and troubleshooting.

### Course Topics

- Introduction to controllers
- CCT Notes
- CCT User Interface
- Troubleshooting Connections

- Modifying Inputs and Outputs
- Simulating Programs
- Peer to Peer
- PID Exploration
- MAP Mobile Access Portal (BACnet Router)
- Online Operations
- Transferring files using SCT
- Transferring files using CCT
- Trunk Utilities
- Commissioning Programs
- Final Review

### Course Duration

Tuesday - Thursday  
Class ends at 3:30 p.m. on Thursday

### Course Fee

\$2915  
per student



[ENROLL NOW](#)



# Metasys® Systems

## Building Standard CCT Programming Course #4803, 3.0 CEU

In this intermediary programming class, students learn standard Johnson Controls programming strategies to write and test programs for Metasys Gen 4 BACnet field devices using the Controller Configuration Tool (CCT.) Once configured, this program will be prepared for a file transfer to a field controller and commissioned to verify proper operations. This course is designed for experienced personnel who want to become proficient in writing and revising programs for Johnson Controls BACnet field devices. Although not a prerequisite, students should be familiar with the topics found in course #4802 or #4703 FEC Operations/Troubleshoot

**Recommended Prerequisites:** Fundamental Control Strategies for HVAC Systems (#215) or equivalent experience.

**For End Users and/or Metasys® Authorized Building Controls Specialists/Contractors only.**

### Course Topics

- CCT User Interface
- Basic Application Creation
- Setting Preferences
- Peer-to-Peer
- Sideloops
- State Tables
- Data Flow and Connections
- Adding Modules
- PRAC+ and PID
- Hands-on Labs
- Final Review
- Final Review

Course Duration
Tuesday - Friday Class ends at 12:00 p.m. on Friday
Course Fee
\$3240 per student



**VIRTUAL COURSES AVAILABLE**

**ENROLL NOW**





# Metasys® Systems

## Optimizing Strategies for CCT Programming Course #4804, 2.0 CEU

In this advanced, three-day programming course, students will learn how to customize standard Controller Application Files (CAF's). Students will learn multiple optimization strategies and their appropriate implementation. The course is designed for experienced building personnel who want to expand their knowledge of HVAC Control Systems and Johnson Controls BACnet field controllers.

### Recommended Prerequisites:

Anyone wishing to enroll in this class it is recommended to have attended Building CCT Programming (#4803 or #3803) or FEC Systems Engineering #4707 and experience using the CCT software.

For End Users and/or Metasys® Authorized Building Controls Specialists/Contractors only.

### Course Topics

- Managing Perspectives
- Module Discovery and Analysis
- Logic and Expression Blocks
- Modifying a Standard Program
- PID and PRAC+
- Hybrid Activity Modules
- State Tables
- Command Hierarchy
- Sequencer and Multi-State Controllers

Course Duration
Tuesday - Thursday Class ends at 3:30 p.m. on Thursday
Course Fee
\$2915 per student

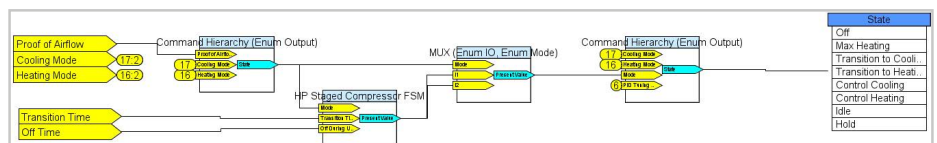

VIRTUAL COURSES AVAILABLE

ENROLL NOW



# Metasys® Systems

## Building and Modifying Metasys® Databases with System - Configuration Tool (SCT) Course #4805, 2.3 CEU

Students learn how to build and program supervisory level controllers. Students will be able to build a complete Metasys® system including Metasys® User Interface for both new and existing sites.

### Recommended Prerequisites:

Due to the material covered in this class, anyone wanting to enroll in this class recommended to have attended courses #389 and either #4707, #3707, #4803 or #3803 as well as #3021

**For End Users and/or Metasys® Authorized Building Controls Specialists/Contractors only.**

### Course Topics

- Network Communications
- Network Design Process and Migration Decisions

- SCT and SCT Pro Overview
- Building an Archive Database
- Design Process for Metasys® UI Site
- Using Rapid Archive Creator (RAC) Wizard
- Modifying Equipment Definitions
- Creating Spaces Using Tailored Summary Viewer
- Configuring VAV Boxes, Air Handling Units and Central Plants
- Use UI Offline to Check your Work
- Demand Limiting/Load Rolling
- Programming Features
- Logic Connector Tool (LCT)
- Associating Graphics

**Course Duration**

Monday - Thursday  
Class ends at 5:00 p.m. on Thursday

**Course Fee**

**\$3240**  
per student

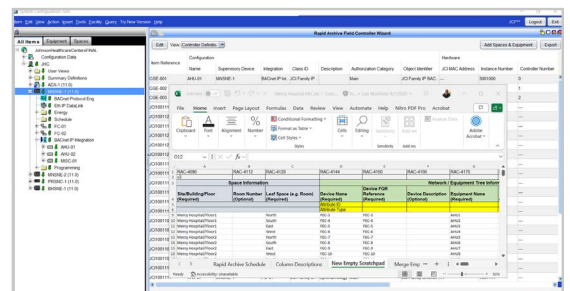

**ENROLL NOW**





# Metasys® Systems

## Metasys® System Extended Architecture Hardware & Troubleshooting Course #4718, 3.0 CEU

This hands-on course provides experienced Metasys® users with valuable diagnostic and troubleshooting skills on system hardware. Discussions and exercises cover the full range of Metasys® Network products, with an emphasis on communication solutions and other commonly experienced problems.

### Recommended Prerequisites:

Due to the material covered in the class, anyone wanting to enroll in this class is required to have had attended courses #389 and #4803/#3803 or 4707 FEC Systems Engineering.

**For End Users and/or Metasys® Authorized Building Controls Specialists/Contractors only.**

### Course Topics

- Metasys® extended architecture Review
- Network Architecture
  - Ethernet Level Connections (BACnet® over IP)

- Controller Trunk Level Connections (BACnet®/MSTP, N2, and LON)
- SA Bus Review
- Network Automation Engines, Network Integration
- Engines and Network Controller Engines Including:
  - NAE common hardware platform
  - NAE Diagnostics, how to run them & evaluate them
- Introduction to the SCT Tool
- Short Review FEC Controller Family; FECs, VMAs and IOM Modules, and TEC Controllers
- Calibrating Sensors and Actuators and Applying Metering Devices
- Downloading Controllers
- Metasys® System Extended Architecture Database overview and organization best practices
- ADS/ADX Servers - their role and features in Metasys® and best practices for backup of data files

### Course Duration

Monday - Friday  
Class ends at 11:30 a.m. on Friday

### Course Fee

\$3565  
per student



**ENROLL NOW**



# Facility Explorer®

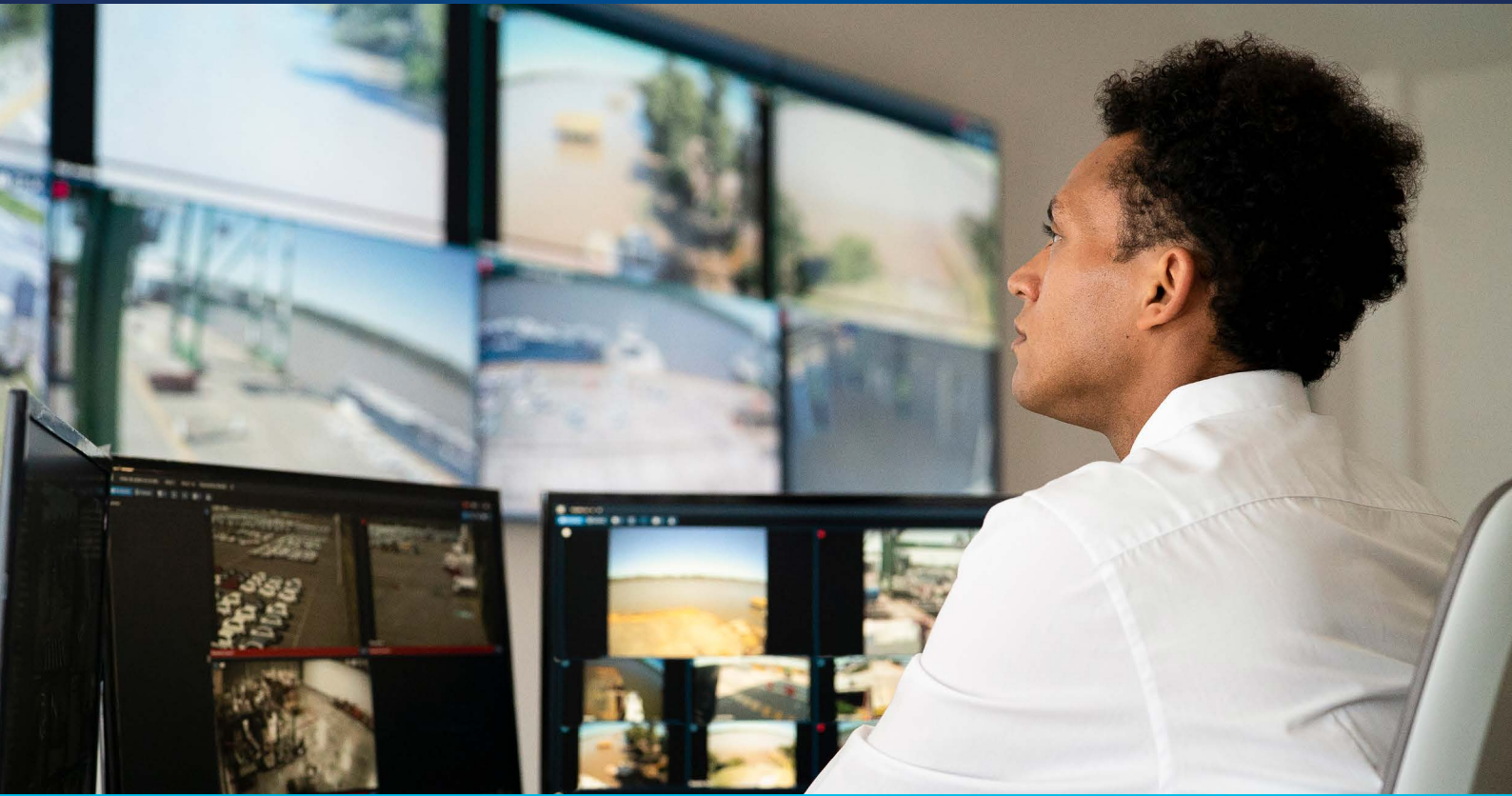

## Facility Explorer® (FX) Field Controller Engineering - Course #4714, 3.0 CEU

Participants will receive an overview of the Facility Explorer (FX) field controller system, create programs from standard tree systems using the Programmable Controller and Commissioning tool, then connect to Bluetooth® and Zigbee® connections and download code into the controllers after setting up the hardware and software to communicate properly.

- Peer-to-Peer
- Mobile Access Portal
- Transferring Files
- IO Commissioning
- Commissioning Programs
- Zigbee® Wireless Communications
- Logic Blocks
- PRAC+ and PID
- Sequencers
- Hands on Labs

**For End Users and/or Facility Explorer® Authorized Building Controls Specialists/ Contractors only.**

### Course Topics

- Intro To The Facility Explorer (FX) Field Controllers System
- Application Creation

Course Duration
Monday - Friday Class ends at 11:30 a.m. on Friday
Course Fee
\$3565 per student



**VIRTUAL COURSES AVAILABLE**

**ENROLL NOW**





# Facility Explorer®

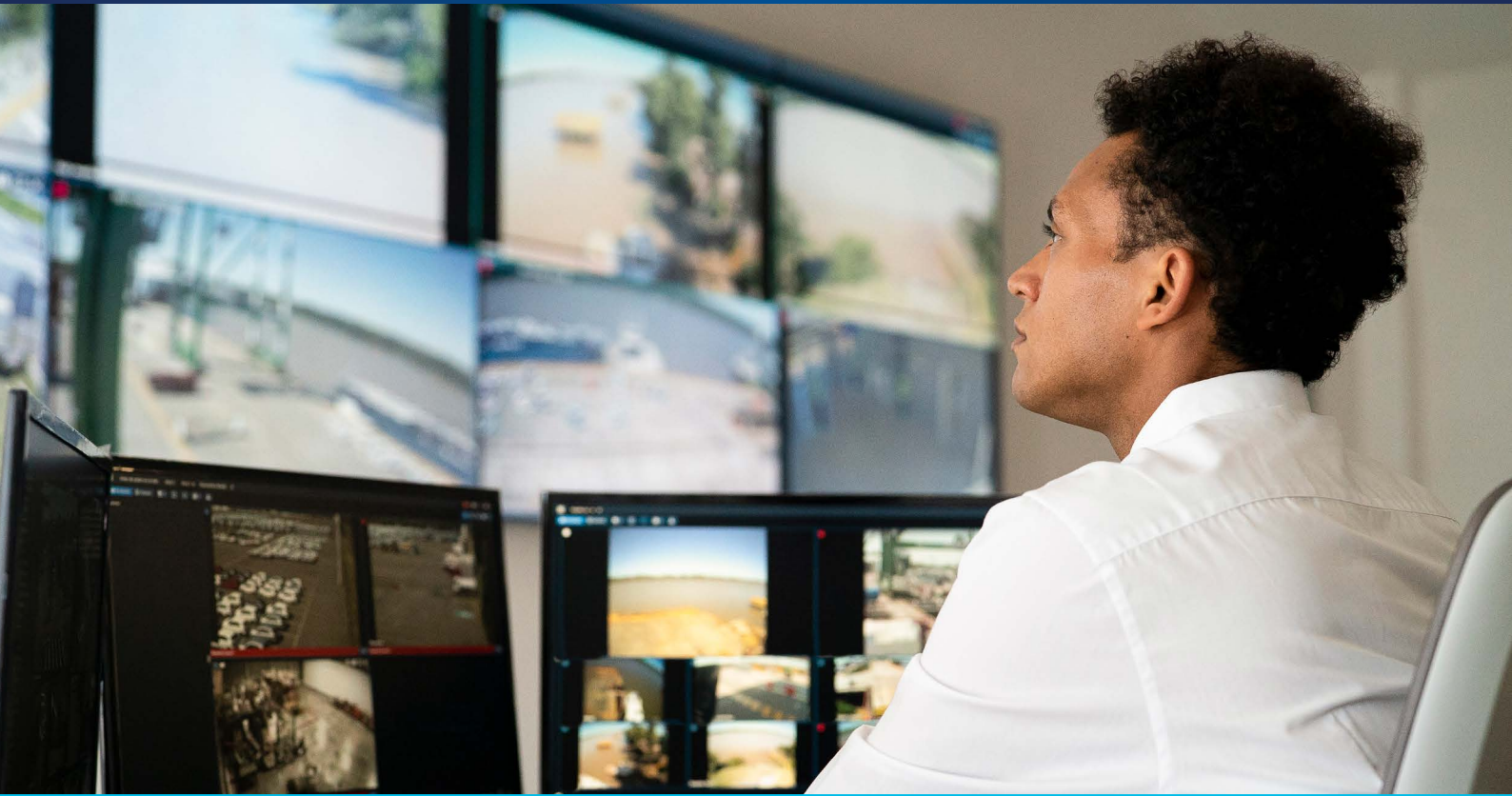

## Facility Explorer® (FX) N4 TCP Certification Course #4720, 3.4 CEU

Basic instruction on design, engineer and program projects using FXWorkbench Pro running on Niagara 4. Testing for Niagara 4 Technical Certification Program (TCP) taken at end of the course.

### Recommended Prerequisites:

Students must have a strong knowledge of Johnson Controls field controllers. A familiarization of building automation systems (BAS) would also be beneficial.

**For End Users and/or Facility Explorer® Authorized Building Controls Specialists/ Contractors only.**

### Course Topics

- Course Introduction and System Overview
- Supervisory Controller User Interface Overview
- FXWorkbench Pro Overview
- Creating a Station
- Adding N2 and BACNet® Controllers and Points
- Extension Manager and Extensions
- Control Logic
- Tagging Objects
- Scheduling
- Defining Users and Roles
- Customizing Access Permissions

### Course Duration

Monday - Friday  
Testing will end at 5:00 p.m. on Friday

### Course Fee

**\$4620**  
per student

- Setting up Email Notification of Alarms
- Graphics
- Controller Summary
- Hierarchy Services
- Commissioning and Backing up a Station
- Auto discovering BACNet® points
- Using Standard Graphics for Other Devices
- Enterprise Connectivity
- Technical Certification Program (TCP) Examination



**VIRTUAL COURSES AVAILABLE**

**ENROLL NOW**





# Instructor-Led Virtual Learning Courses







## Instructor-Led Virtual Learning Courses

### Metasys® User Interface Graphics Editor Course #3022

This course is designed for customers who have experience with the Metasys® User Interface, but want or need to learn how to create Metasys® UI Graphics. After completing this course, participants will be able to navigate the Metasys® Graphics Manager, import and export graphics and associate a graphics to a space, equipment definition, or piece of equipment and add custom behaviors to a graphic.

#### Course Topics

- Access the Graphics Manager through the User Online/Offline
- Navigate the Graphics Manager
- Import and export graphics using the Offline User Interface
- Navigate through the Graphics Editor
- Create and edit the Master Layer for a site

- Create, edit, and associate a graphic to a space or piece of equipment
- Create and edit a floorplan
- Create and edit user defined graphics templates
- Add custom behaviors to graphics

#### Course Duration

One Day

#### Course Fee

\$1025  
per student

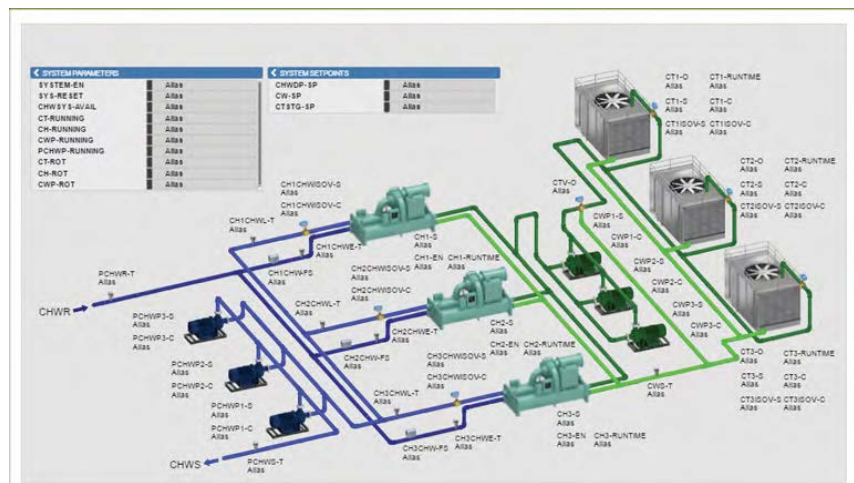

[ENROLL NOW](#)



## Instructor-Led Virtual Learning Courses

### Programming & Engineering EasyIO® Controllers with CPT Tools Course #3024

EasyIO is a robust and flexible line of IP-based controllers. The participant will be able to identify various EasyIO controller types and uses for each. Additionally the participant will write programming logic, set up dashboards and graphics, as well as integrate various protocols. The Course will be delivered virtually over the period of 4 days in 4 hour increments, an AM or p.m. session. The total training will be 16 hours. When registering please note that you are registering for an AM or p.m. session, not both.

#### Required Hardware

- Laptop computer running Windows 7 or higher operating system
- (3) Network patch cords
- (1) Network switch
- (1) FS Series Controller (Preferably the FS-20)

- (1) FW Series Controller (Preferably the FW-8)
- (1) 24 VAC Power Supply to power the controllers at the same time
- HTML-5 Compatible Web Browser (Chrome Preferred)
- CPT Tools (Supplied by Instructor)

#### Course Topics

- EasyIO Product Fundamentals
- Programming the FW-Series and FS-Series Controllers
- BACnet IP Server and BACnet Client
- Dashboards
- Backup / Restore Functions
- P2P Communications
- Apps Tool
- Graphics
- SQLite Database and Charts

#### Course Duration

16 hours over 4 days  
AM Session Starts at 8:00 CST  
PM Session Starts at 1:00 CST

#### Course Fee

\$850 per student

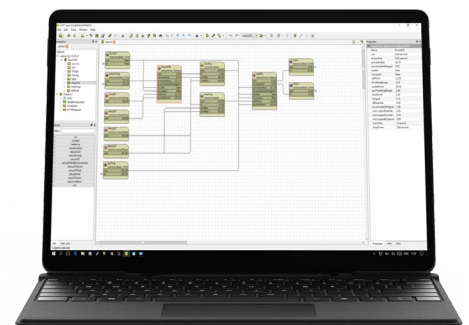

**ENROLL NOW**





## Instructor-Led Virtual Learning Courses

### Optimizing Strategies for CCT Programming with Facility Explorer Systems #3028

In this advanced, three-day programming course, students will learn how to customize standard FX BACnet controller programs. Students will learn multiple optimization strategies and their appropriate implementation. The course is designed for experienced building personnel who want to expand their knowledge of HVAC Control Systems and Johnson Controls BACnet field controllers.

#### Recommended Prerequisites:

4714 - FX MSTP Field Controller Engineering and experience using the CCT software prior to attending.

For End Users and/or FX Authorized Building Controls Specialists/Contractors Only.

#### Course Topics

- Managing Perspectives
- Module Discovery and Analysis
- Logic and Expression Blocks
- Modifying a Standard Program
- PID and PRAC+
- Hybrid Activity Modules
- State Tables
- Command Hierarchy
- Sequencer and Multi-State Controllers

Software Requirements: CCT 14.2 or later with all packages installed on your computer prior to attending the training.

#### Course Duration

Tuesday - Thursday  
Class ends at 3:30 p.m. on Thursday

#### Course Fee

\$1945  
per student

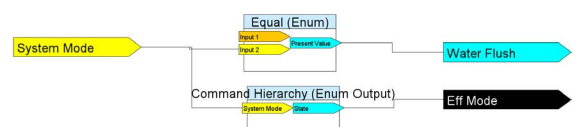

ENROLL NOW



## Instructor-Led Virtual Learning Courses

### YK High Pressure Centrifugal Operations/Maintenance Course #3102

Students will learn about the internal workings of the YK high-pressure centrifugal single-stage compressor, oil return system, OptiView Control Center, and other components and subsystems. A comprehensive review of the preventive maintenance schedule and system capacity checkout procedure is also covered.

- Maintenance
- OptiView operation: screen navigation, interpretation, and modification
- Troubleshooting
- Warranty
- Evaluating chiller
- Simulator demonstration

#### Course Topics

- Centrifugal compressor theory of operation Controller Tool (PCT)
- YK chiller design and component functionality
- YK seasonal start-up
- OptiView basics: application, terminology
- OptiView architecture: component identification, component location

#### Course Duration

Tuesday - Thursday  
Class ends at 3:30 p.m. on Thursday

#### Course Fee

\$1945  
per student



[ENROLL NOW](#)





## Instructor-Led Virtual Learning Courses

### YCAV Air Cooled Rotary Screw Liquid Chillers Course #3103

This three-day course teaches service personnel about the YCAV Chiller features, including the screw compressor, system ancillary components, unit operation, and maintenance.

#### Course Topics

- Navigating the new User Interface
- Screw chiller basics
- Basic electronics
- VSD basics
- VSD and control panel architecture
- Operation and sequencing
- Latitude simulator exercises
- Information and safety, handling and storage
- VSD operation and faults
- Maintenance
- Unit troubleshooting
- Simulator demonstration

#### Course Duration

Tuesday - Thursday  
Class ends at 3:30 p.m. on Thursday

#### Course Fee

\$1945  
per student



[ENROLL NOW](#)



## Instructor-Led Virtual Learning Courses

### Absorber Operations/Maintenance Course #3104

This course teaches operators and technicians about the operation and controls associated with YORK® lithium bromide absorption chillers. Absorption theory, including P/T relationships and solution chemistry, is also covered. The operation and operating procedures for both Isoflow (single stage) and Paraflow systems (two stage) are reviewed with an emphasis on preventive maintenance procedures.

#### Course Topics

- Basic refrigeration principles
- Units of measure, types of heat
- Absorption principles
- Solution chemistry
- YIA components and cycle
- Water circuits
- YPC components and cycle
- YPC purge system
- Operating information, setpoints and warnings

- System and safety cycling shutdowns
- Operation and maintenance
- Crystallization
- Unit operation and operational limitations
- Refrigerant contamination
- Heating/cooling changeover
- Preventive maintenance
- Schedules

#### Course Duration

Tuesday - Thursday  
Class ends at 3:30 p.m. on Thursday

#### Course Fee

\$1945  
per student



[ENROLL NOW](#)





## Instructor-Led Virtual Learning Courses

### YVAA Air Cooled Screw Chiller Course #3111

This three-day course teaches experienced service technicians about the YVAA Chiller. The course will include features of this unit and the differences in installation, operation and maintenance from the YCAV.

#### Course Topics

- Chiller layout and components
- Safety and handling
- Installation
- Operation/Maintenance
- VSD
- Simulation demonstration

#### Course Duration

Tuesday - Thursday  
Class ends at 3:30 p.m. on Thursday

#### Course Fee

\$1945  
per student



[ENROLL NOW](#)



## Instructor-Led Virtual Learning Courses

### YLAA Chiller Start-Up and Troubleshooting Course #3114

Students will learn the techniques, strategies and skills required to operate, repair, start up and maintain the YORK® YLAA chiller and YLPA heat pump chillers using multiple scroll compressors in each system. The techniques acquired in this course may be applied to other YORK® small-tonnage chillers and condensing units such as YCAL, YLUA, and YCUL models.

#### Course Topics

- Safety
- Literature
- Theory
- Components
- Operations
- Wiring diagrams
- Installation
- Start-up
- Maintenance
- Evaluating performance
- Warranty

#### Course Duration

Tuesday - Thursday  
Class ends at 3:30 p.m. on Thursday

#### Course Fee

\$1945  
per student



[ENROLL NOW](#)





## Instructor-Led Virtual Learning Courses

### Metasys® System Extended Architecture for Building Operators Course #3388

This four-day course teaches building personnel how to make the most effective and efficient use of the features of a Metasys® extended architecture building management system. This course is for building personnel who have Site Management Portal (SMP™ installations of Metasys® system extended architecture).

#### Course Topics

- Metasys® system extended architecture overview
- Help file system
- Basic navigation of the system with the User Interface
- Commanding objects

- Scheduling
- Setting up alarms
- Responding to alarms
- Trending
- Totalization
- Graphics
- Hands-on lab
- Final review

#### Course Duration

Tuesday - Friday  
Class ends at 3:30 p.m. on Friday

#### Course Fee

\$1965  
per student

Status	Item	Value	Description
High Alarm	ZN-T	82.1 deg F	Zone Temperature
	OCC-SCHEDULE	Occupied	Occupied Command
	SF-C	On	Supply Fan Command
	SF-S	On	Supply Fan Status
	DA-T	54.9 deg F	Discharge Air Temperature
	DAT-SP	55.0 deg F	Discharge Air Temperature Setpoint
	CLG-O	99 %	Cooling Valve Output
	PH-O	0 %	Preheat Valve Output
	FILT-S	Clean	Filter Status
	DA-SD	Normal	Discharge Air Smoke Alarm
	LT-A	Normal	Low Temperature Alarm

[ENROLL NOW](#)



## Instructor-Led Virtual Learning Courses

### Building Standard CCT Programming Course #3803

In this intermediary programming class, students learn standard Johnson Controls programming strategies to write and test programs for Metasys Gen 4 BACnet field devices using the Controller Configuration Tool (CCT.) Once configured, this program will be prepared for a file transfer to a field controller and commissioned to verify proper operations. This course is designed for experienced personnel who want to become proficient in writing and revising programs for Johnson Controls BACnet field devices. Although not a prerequisite, students should be familiar with the topics found in course #4703/4802.

#### Recommended Prerequisites:

Fundamental Control Strategies for HVAC Systems (#215) or equivalent experience.

For End Users and/or Metasys Authorized Building Controls Specialists/Contractors only.

#### Course Topics

- CCT User Interface
- Basic Application Creation
- Setting Preferences
- Peer-to-Peer
- Sideloops
- State Tables
- Data Flow and Connections
- Adding Modules
- PRAC+ and PID
- Hands-on Labs
- Final Review

Students enrolling in the class will attend via distance learning and will be required to have the following available.

- PC with CCT installed (v14.2 or later), fully licensed and operationa

#### Course Duration

Tuesday - Friday  
Class ends at 3:30 p.m. on Friday

#### Course Fee

\$1965  
per student



[ENROLL NOW](#)





## Instructor-Led Virtual Learning Courses

### Optimizing Strategies for CCT Programming Course #3804

In this advanced, three-day programming course, students will learn how to customize standard Controller Application Files (CAF's). Students will learn multiple optimization strategies and their appropriate implementation. The course is designed for experienced building personnel who want to expand their knowledge of HVAC Control Systems and Johnson Controls BACnet field controllers.

#### Recommended Prerequisites:

Anyone wishing to enroll in this class it is recommended to have attended Building CCT Programming (#4803 or #3803) or FEC Systems Engineering #4707 and experience using the CCT software.

#### Software Requirements:

CCT 15.0 or later with all packages installed on our computer prior to attending.

**For End Users and/or Metasys® Authorized Building Controls Specialists/Contractors only.**

#### Course Topics

- Managing Perspectives
- Module Discovery and Analysis
- Logic and Expression Blocks
- Modifying a Standard Program
- PID and PRAC+
- Hybrid Activity Modules
- State Tables
- Command Hierarchy
- Sequencer and Multi-State Controllers

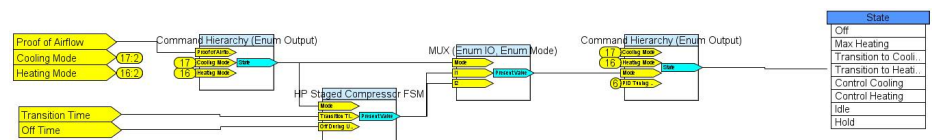

#### Course Duration

Tuesday - Friday  
Class ends at 3:30 p.m. on Friday

#### Course Fee

\$1965  
per student

Students enrolling in the class will attend via distance learning (Zoom) and will be required to have the following available.

- PC with CCT installed (v14.2 or later) fully licensed and operational

**ENROLL NOW**



# Instructor-Led Virtual Learning Courses

## Facility Explorer® (FX) Field Controller Engineering Course #3714

After completing this course, Participants will receive an overview of the Facility Explorer (FX) field controller system, create programs from standard tree systems using the Controller and Commissioning tool.

- Zigbee (copyright) Wireless Communications
- Logic Blocks
- PRAC+ and PID
- Sequencers
- Hands on Labs

**Software Requirements: CCT 15.0 or later with all packages installed on your computer prior to attending.**

### Course Topics

- Intro To Facility Explorer Field Controllers System
- Application Creation
- Peer-to-Peer
- Mobile Access Portal
- Transferring Files
- IO Commissioning
- Commissioning Programs

### Course Duration

Monday - Friday  
Class ends at 11:30 a.m. on Friday

### Course Fee

\$2115  
per student

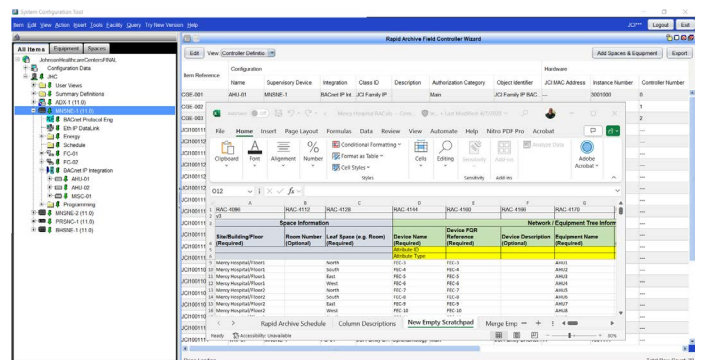

**ENROLL NOW**





## Instructor-Led Virtual Learning Courses

### Facility Explorer® (FX) N4 TCP Certification Course #3720

Basic instruction on design, engineering and programming projects using FXWorkbench Pro running on Niagara 4. This includes creating stations, adding various controller protocols and controllers, creating graphics, adding schedules, configuring users, using wiresheets, commissioning the FX80, and more. Testing for Niagara 4 Technical Certification Program (TCP) taken at end of the course.

#### Recommended Prerequisites:

Students must have a strong knowledge of Johnson Controls field controllers. A familiarization of building automation systems (BAS) would also be beneficial.

**For End Users and/or Facility Explorer® Authorized Building Controls Specialists/Contractors only.**

#### Course Topics

- Introduction to Facility Explorer
- Station Creation
- Defining JCI Controllers
- Equipment and Spaces
- Tag Dictionaries / Tagging
- Hierarchies
- Extensions
- Control Logic
- Permissions
- Graphics
- Commissioning an FX80
- Enterprising
- N4 TCP Exam

#### Course Duration

Monday - Friday  
Class ends at 5:00 p.m. on Friday

#### Course Fee

\$3320  
per student

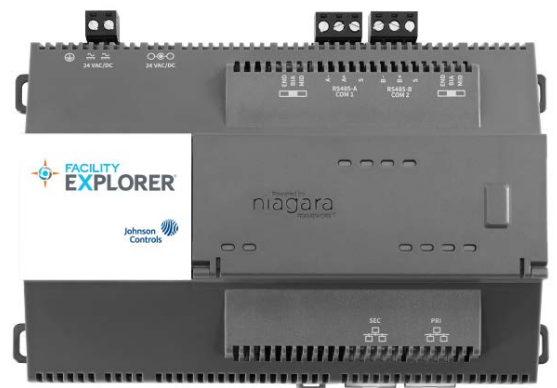

**ENROLL NOW**



## Instructor-Led Virtual Learning Courses

### Building an FX Supervisory Network Controller (SNC) Course #3821

This introductory course imparts foundational knowledge of database creation using the System Configuration Tool (SCT and SCT Pro). The student will learn about the FX Supervisory Plant Controller (SNC). The Rapid Archive Creator (RAC) is used to prepare and build a database framework, and students learn how to complete the database after RAC implementation. Students will prepare a SNC for database transfer. Using SCT and SCT Pro to transfer Controller Application Files (CAF) to Field Controllers is also covered.

#### Course Topics

- JCI FX Supervisory Plant Controller (SNC) hardware overview
- SCT and SCT Pro overview
- Archive Database Structure
- Using Rapid Archive Creator (RAC) to assist automated database building
- Preparing the SNC

- Using SCT/SCT Pro to transfer controller configuration file into the SNC
- Archiving databases from SNC and Field Controllers

#### Software Requirements

This is a virtual class so the student will be responsible for supplying equipment for the learning opportunity including:

- Personal Computer with the following software installed and licensed
  - CCT 14.0 (or later)
  - SCT 14.1 (or later)
  - FX Device Packages for SCT
  - FX Field Controller Packages
  - Johnson Controls SA Bus Device Packages
- 2515x-0 or 2515x-OH with 24 VAC power ready for operation

#### Course Duration

Tuesday - Friday  
Class ends at 3:30 p.m. on Friday

#### Course Fee

\$1760  
per student



[ENROLL NOW](#)





## Courses Offered By Request Only





## Courses Offered By Request Only



The following courses are only available at your request. They can usually be conducted at your site or at one of our Training Institute locations with a minimum of eight students. These courses are not included in the Learning Catalog schedule at the back of this publication. For more information about the content, availability and pricing of these courses, call the Training Institute Registrar at 800-524-8540 or 414-524-4286 or email at [cg-customer.registrar@jci.com](mailto:cg-customer.registrar@jci.com)

### Metasys® HVAC ASC Engineering Course #353, 3.0

Experienced DX-9100 users will learn how to create and modify the DX-9100 application programs using Windows-based GX-9100 software. This course is a follow-up to the Metasys® DX-9100 Operations/Troubleshooting course for students who want to develop their skills in programming and troubleshooting their DX-9100 system.

### Metasys® DX-9100 Engineering Course #364, 3.0

This course covers programming and testing control strategies for Application Specific Controllers (ASCs). The course is designed for experienced building personnel who want to expand their knowledge of HVAC Control Systems and Johnson Controls ASC devices.

### Metasys® DX-9100 Operations/Troubleshooting Course #365, 2.0

This introductory course teaches participants how to communicate and troubleshoot effectively using the DX-9100. This course is highly recommended for anyone involved in the day-to-day operation of a DX-9100 system.





## Courses Offered By Request Only



The following courses are only available at your request. They can usually be conducted at your site or at one of our Training Institute locations with a minimum of eight students. These courses are not included in the Learning Catalog schedule at the back of this publication. For more information about the content, availability and pricing of these courses, call the Training Institute Registrar at 800-524-8540 or 414-524-4286 or email at [cg-customer.registrar@jci.com](mailto:cg-customer.registrar@jci.com)

### **Metasys® HVAC ASC Operations/Troubleshooting Course #381, 3.0**

Students will learn about the Application Specific Controllers (ASC) used at their facility. Extensive hands-on lab activities use HVACPRO software to work with AHU, UNT, VAV and VMA controllers for troubleshooting programs and field devices.

### **YVWA Water Cooled Screw Chiller\* Course #2112, 2.0**

This two-day course teaches experienced service technicians about the YVWA Chiller. The course will include features of this unit and the differences in installation, operation and maintenance from the YCAV. \*Dress code: For safety, closed-toe, leather shoes and long pants are required.



# How to Enroll in A Course



## Enroll Online

Register and purchase trainings online with credit cards, all at one location.

[www.jcittraininginstitute.com](http://www.jcittraininginstitute.com)



## Browse Our Courses & Schedule

Check classes that are open for enrollment and check the current status of a class.

[www.johnsoncontrols.com/institute](http://www.johnsoncontrols.com/institute)







# Johnson Controls Training Institute: Course Application

We encourage you to register for classes online at: [www.jcittraininginstitute.com](http://www.jcittraininginstitute.com). This form should be used by those unable to register online, such as government agencies, and Johnson Controls branch offices. You can fill the form out then print this page and either email ([cg-customer.registrar@jci.com](mailto:cg-customer.registrar@jci.com)) or fax (877-403-6625) it to the Johnson Controls Training Institute.

## Student Information

Name of Applicant (Please Print)

Student E-mail Address (REQUIRED FOR CONFIRMATION / CANCELLATION NOTIFICATION)  
Please provide a unique email address for each applicant.

Company/Organization Name

Company/ Organization Address (No P.O. Box)

City  State  Zip

Telephone Number (  )  -

## Course Registration Information

Course Name

Course #  Location

First Choice Date

Second Choice Date

Payment must be received 10 days prior to course start date.

Payment Method Selected:  
 Visa® or     MasterCard® or     American Express®

#  Exp. Date

\_\_\_\_\_

(Signature) (Email address to send receipt)

**Tax Deduction**  
U.S. Treasury Regulation 1.162.5 permits an income tax deduction for educational expenses incurred to maintain or improve professional skills. Consult your tax advisor for details.

**For Johnson Controls Branch Use Only**  
Installation Contract #

## Cancellation Policy

Refunds are issued only if you notify the Institute at 414-524-4286 or 800-524-8540 that you cannot attend, no less than ten business days prior to the start of the course. You are liable for the entire course fee if cancellation is received after this deadline; you may substitute another student. Johnson Controls reserves the right to cancel classes and assumes no liability for expenses, all registrants will be notified at least ten days before the start of class.



**Telephone:**  
414-524-4286  
800-524-8540



**Fax:**  
877-403-6625



**Internet:**  
[www.johnsoncontrols.com/institute](http://www.johnsoncontrols.com/institute)

# Johnson Controls Institute

## 2025 Class Schedule

January - June (July - December on reverse side)

FOR MORE INFORMATION: [www.johnsoncontrols.com/institute](http://www.johnsoncontrols.com/institute)

These dates are subject to change. Please verify the dates and location and look for new course offerings at [www.jcitraininginstitute.com](http://www.jcitraininginstitute.com)

Course Name	Course #	Start-End	Course Fee	January				February			March				April				May			June						
				1	6	13	20	27	3	10	17	24	3	10	17	24	31	7	14	21	28	5	12	19	26	2	9	16
<b>HVAC INDUSTRY COURSES</b>																												
HVAC Mechanical Systems	210	M-F	\$3,565																									
Fundamental Control Strategies for HVAC Systems	215	M-F	\$3,565							TAM																		
HVAC Pneumatic Controls - Multi Manufacturer	221	Tu-Th	\$2,915																									
HVAC Equipment Maintenance	225	Tu-Th	\$2,915																									
OptiView™ Control Panel	2100	Tu-W	\$2,160																									
YK High Pressure Centrifugal Operations/Maintenance	2102	Tu-Th	\$2,915																									
YCAV Air Cooled Rotary Screw Liquid Chillers	2103	Tu-Th	\$2,915																									
Absorber Operations/Maintenance	2104	Tu-Th	\$2,915																									
YT/YK Centrifugal Chiller and Compressor Overhaul	2107	M-F	\$3,510																									
YPAL Series 100 Package RTU	2108	Tu-Th	\$2,915																									
YVAA Air Cooled Screw Chiller	2111	Tu-Th	\$2,915																									
YLAA Chiller Start-Up and Troubleshooting	2114	Tu-Th	\$2,915																									
<b>Building Automation Systems Courses</b>																												
Metasys® System Extended Architecture for Building Operators	388	M-W	\$2,915																									
Metasys® System Extended Architecture for Building Engineers	389	M-F	\$3,565																									
Metasys® System Extended Architecture Advanced Engineering	397	Tu-Th	\$2,915																									
Facility Explorer® (FX) Field Controller Engineering	4714	M-F	\$3,565																									
Metasys® System Extended Architecture Hardware and	4718	M-F	\$3,565																									
Facility Explorer® (FX) N4 TCP Certification	4720	M-F	\$4,620																									
Metasys® User Interface (UI) for Building Operators	4800	T-W	\$2,160																									
Metasys® User Interface (UI) for Building Engineers	4801	T-F	\$3,240																									
Learning CCT Hardware and Commissioning	4802	Tu-Th	\$2,915																									
Building Standard CCT Programming	4803	Tu-F	\$3,240																									
Optimizing Strategies for CCT Programming	4804	Tu-Th	\$2,915																									
Metasys® Database with System Configuration Tool (SCT)	4805	M-Th	\$3,240																									
<b>Virtual Instructor Led Training</b>																												
<b>HVAC INDUSTRY COURSES</b>																												
YK High Pressure Centrifugal Operations/Maintenance	3102	Tu-Th	\$1,945																									
YCAV Air Cooled Rotary Screw Liquid Chillers	3103	Tu-Th	\$1,945																									
Absorber Operations/Maintenance	3104	Tu-Th	\$1,945																									
YVAA Air Cooled Screw Chiller	3111	Tu-Th	\$1,945																									
YLAA Chiller Start-Up and Troubleshooting	3114	Tu-Th	\$1,945																									
<b>Building Automation Systems Courses</b>																												
Metasys® User Interface Graphic Editor	3022	Th	\$1,025																									
EasyIO CPT Tools and F-Series Training	3024	Tu-F	\$850																									
Optimizing Strategies for CCT Programming with Facility	3028	Tu-Th	\$1,945																									
Metasys® System Extended Architecture for Building Operators	3388	Tu-F	\$1,965																									
Building CCT Programming	3803	Tu-F	\$1,965																									
Optimizing Strategies for CCT Programming	3804	Tu-F	\$1,965																									
Facility Explorer® (FX) Field Controller Engineering	3714	M-F	\$2,115																									
Facility Explorer® (FX) N4 TCP Certification	3720	M-F	\$3,320																									
Building an FX Supervisory Network Controller (SNC)	3821	Tu-F	\$1,965																									

KEY for INSTITUTE LOCATIONS: BOS (Boston) DAL (Dallas) VL (Virtual Learning) HOU (Houston) MKE (Milwaukee) LOU (LOUISVILLE) PHX (Phoenix) TAM (Tampa) NF(New Freedom, PA)







## 2025 Customer Training Catalog

[www.johnsoncontrols.com/institute](http://www.johnsoncontrols.com/institute)

800-524-8540, 414-524-4286 or email us at [cg-customer.registrar@jci.com](mailto:cg-customer.registrar@jci.com)

Johnson Controls, the Johnson Controls logo, YORK®, Metasys® and Eaton® are all registered trademarks, and OptiView™ is a trademark of Johnson Controls, Inc. or its affiliates, in the United States of America and/or other countries. Microsoft and Windows are either registered trademarks or trademarks of Microsoft Corporation in the United States and/or other countries.

PUBL - 2211- EN2025